

BACK ASSEMBLY INSTRUCTIONS FOR HEMTT SEATS

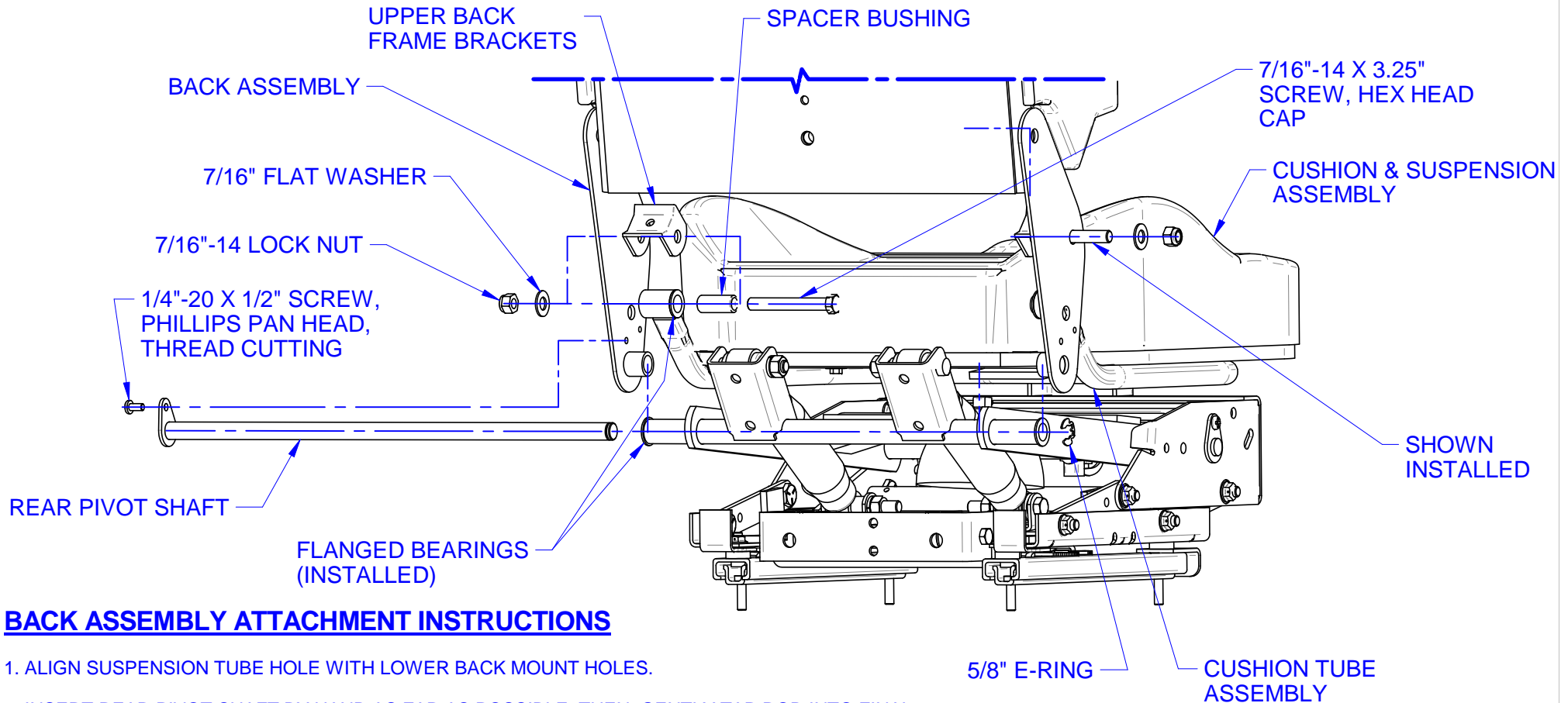

BACK ASSEMBLY ATTACHMENT INSTRUCTIONS

1. ALIGN SUSPENSION TUBE HOLE WITH LOWER BACK MOUNT HOLES.
2. INSERT REAR PIVOT SHAFT BY HAND AS FAR AS POSSIBLE. THEN, GENTLY TAP ROD INTO FINAL POSITION, BEING CAREFUL NOT TO DAMAGE FLANGED BEARINGS.
3. SECURE REAR PIVOT SHAFT WITH 1/4'-20 PHILLIPS PAN HEAD, THREAD CUTTING SCREW, USING PHILLIPS SCREWDRIVER.
4. INSERT 5/8" E-RING ON TO THE OTHER END OF REAR PIVOT SHAFT.
5. INSERT SPACER BUSHINGS INTO FLANGED BEARINGS IN CUSHION TUBE ASSEMBLY.
6. ALIGN UPPER BACK FRAME BRACKETS WITH CUSHION TUBE ASSEMBLY.
7. INSERT (2) 7/16"-14 X 3.25" HEX HEAD CAP SCREWS. ASSEMBLE BELTS AND SECURELY TIGHTEN WITH 7/16" FLAT WASHERS AND 7/16"-14 LOCK NUTS, PER NORMAL OSHKOSH PROCEDURES.

REFERENCE: 177604

SEATS INC. ASSUMES NO RESPONSIBILITY FOR DAMAGE OR INJURY CAUSED BY IMPROPER SPACING TO VEHICLE CONTROLS OR INSTALLATION METHOD. THIS IS ONLY A GUIDELINE AND DOES NOT GUARANTEE SATISFACTORY SEAT FUNCTION DUE TO INCOMPLETE OR IMPROPER INSTALLATION. PARTS SUPPLIED BY **SEATS INC.** ARE COVERED BY A LIMITED WARRANTY.

seats

SIZE: A DRAWN BY: KBB
DATE: 1/10/2014 REV. 00 DWG. NO. 6122_00

Seats Incorporated
1515 Industrial Street
Reedsburg, WI 53959
(608) 524-4316
Fax: 608-524-6004
Toll Free: 1-800-443-0615