

ITEM	PN	DESCRIPTION	QTY
1	384094	CAM SUSPENSION ASSY	1
2	513912	CONTROL PANEL	1
3	513913	RH SEAT VALVE BKT	1
4	513933	AIR VALVE BKT	1
5	707130	PADDLE AIR VALVE	1
6	707196	SCREW, 1/4-20X3/4, SEMS, HWH, BLKZC	2
7	781846	SCREW, 1/4-14X5/8, HWH, T/S, TAB, TRIBLK	2
8	782380	UNION, 1/4 STRAIGHT, PTC	1
9	707754	AIR HOSE, 1/4"OD, PLASTIC, DOT-RATED	1
10	515760	OWNER'S MANUAL GENERIC LABEL	1

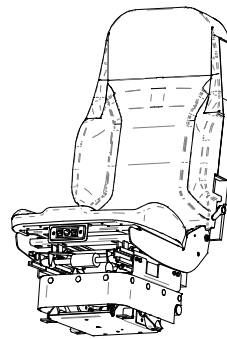

FOR SEATS WITH 6-WAY RISER,
(SEE INSTRUCTIONS ON SHEET 2)

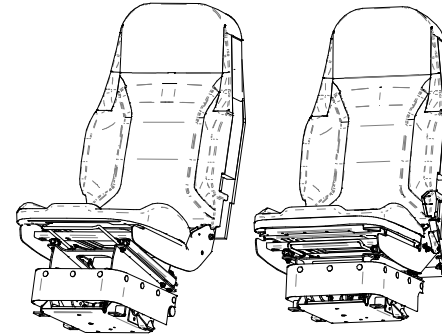

FOR SEATS WITH METAL PANS,
(SEE INSTRUCTIONS ON SHEET 3)

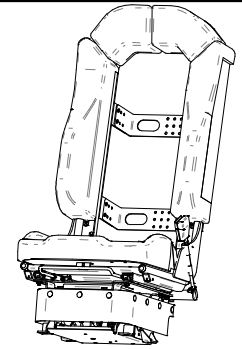

FOR SEATS WITH WOOD BOARDS,
(SEE INSTRUCTIONS ON SHEET 4)

SEATS NUMBER / PIERCE NUMBER
180000 / 1640006

SEATS NUMBER / PIERCE NUMBER
180002 / 1640008 or 2234441
180014 / 1640017

SEATS NUMBER / PIERCE NUMBER
180010 / 1640014
182300 / 2030570
182301 / 2030566
182302 / 2030564
182303 / 2030568

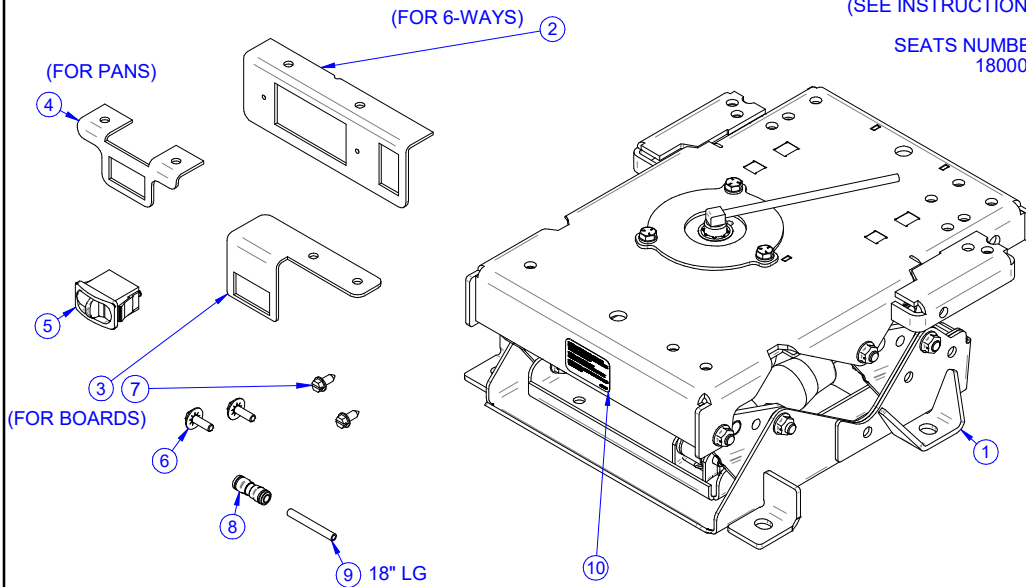

THIS KIT IS TO REPLACE SELF-LEVELING SUSPENSION SEATS #180094PS / PIERCE # 1825553.

REV	DESCRIPTION	DATE	APPROVED
1	ADD 515760 DECAL - ECR 115856	05/29/19	AMR
REVISIONS			
DIMENSIONAL TOLERANCES UNLESS OTHERWISE SPECIFIED: FRACTIONAL ± 1/2" 3 PLACE DECIMALS ± .010 2 PLACE DECIMALS ± .030 1 PLACE DECIMALS ± .50 ANGLES ± 1.0° INTERNAL FEATURES ± .003		 SEATS INCORPORATED 1515 INDUSTRIAL ST. REEDSBURG, WI 53959	
DRAWN BY SLS		DATE 12/21/16	
APPROVED BY		DATE	
FILE NAME 186094-01.dft		SIZE B	FSCM NO. PART NO. 09704 186094
DO NOT SCALE PRINT			EST WEIGHT 36.401 lbm SHEET 1 OF 4

PLEASE NOTE
This drawing, owned by Seats Incorporated Reedsburg, WI, is conditionally loaned and its disclosure to the recipient is in confidence. In receiving it, the recipient agrees not to reproduce or copy it in whole or part without written consent or to furnish information from it to others or to make any use of it that is, or may be injurious or damaging to Seats Incorporated in any way, and to return it immediately upon request. Seats Incorporated

EFF. DATE: 06/18/19

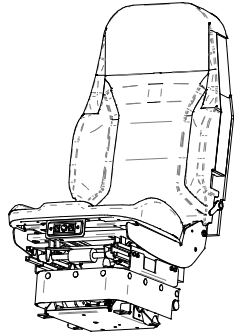

FOR SEATS WITH 6-WAY RISER,

REPLACEMENT INSTRUCTIONS

1. REMOVE (2) BOLTS AND WASHERS HOLDING RISER TO SUSPENSION, REMOVE ICP, SET ASIDE.
2. REMOVE (6) BOLTS AND WASHERS HOLDING RISER TO SUSPENSION.
3. REMOVE SEAT UPPER AND RISER ASM, SET ASIDE.
4. REMOVE SKIRT WITH BRACKET OFF SUSPENSION, SET ASIDE.
5. CUT EXISTING AIR SUPPLY LINE CLOSE TO AIR SPRING.
6. REMOVE OLD SUSPENSION FROM FLOOR, DISCARD.
7. INSTALL NEW REPLACEMENT SUSPENSION TO FLOOR.
8. PLACE SKIRT WITH BRACKET ON NEW SUSPENSION, ALIGNING HOLES.
9. REPLACE AIR SUPPLY HOSE, OR ADD 18" HOSE WITH UNION TO EXISTING SUPPLY.
10. REMOVE ORIGINAL CONTROL BRACKET FROM UNDER CUSHION. REMOVE WIRING FROM BACK OF CONTROLS, REMOVE CONTROLS FROM OLD BRACKET, RE-INSTALL CONTROLS INTO NEW BRACKET. INSTALL AIR PADDLE VALVE IN BRACKET.
11. SCREW NEW BRACKET TO CUSHION PAN, RE-CONNECT CONTROL WIRING.
12. PLACE SEAT UPPER & RISER ASM ON SUSPENSION & SKIRT. RE-INSTALL (6) SCREWS AND WASHERS TO SUSPENSION.
13. CONNECT AIR SUPPLY HOSE (BLUE) TO PADDLE VALVE. CONNECT HOSE (BLACK) FROM AIR SPRING TO PADDLE VALVE.
14. RE-ATTACH ICP WITH (2) SCREWS AND WASHERS TO SUSPENSION.
15. BE SURE ALL HARDWARE HAS BEEN SECURELY FASTENED.
16. INSPECT AND TEST ALL FUNCTIONS.

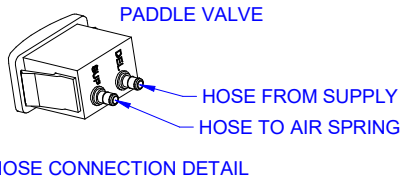
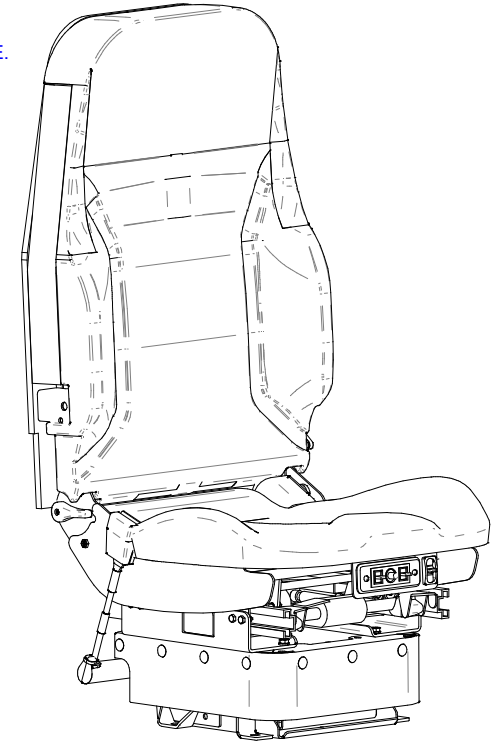

PLEASE NOTE
 This drawing, owned by Seats Incorporated Reedsburg, WI, is conditionally loaned and its disclosure to the recipient is in confidence. In receiving it, the recipient agrees not to reproduce or copy it in whole or part without written consent or to furnish information from it to others or to make any use of it that is, or may be injurious or damaging to Seats Incorporated in any way, and to return it immediately upon request. Seats Incorporated

REV	DESCRIPTION	DATE	APPROVED
REVISIONS			
DIMENSIONAL TOLERANCES UNLESS OTHERWISE SPECIFIED: FRACTIONAL ± 1/2" 3 PLACE DECIMALS ± .010 2 PLACE DECIMALS ± .030 1 PLACE DECIMALS ± .50 ANGLES ± 1.0° INTERNAL FEATURES ± .003		 SEATS INCORPORATED 1515 INDUSTRIAL ST. REEDSBURG, WI 53959	
DRAWN BY		DATE	
APPROVED BY		DATE	
FILE NAME: 186094-01.dft		SIZE: B FSCM NO: 09704 PART NO: 186094	TITLE CAM SUSPENSION REPLACEMENT KIT
DO NOT SCALE PRINT		EST WEIGHT: 36.401 lbm	SHEET 2 OF 4

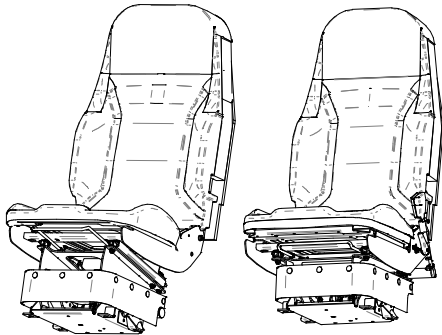

FOR SEATS WITH METAL PANS

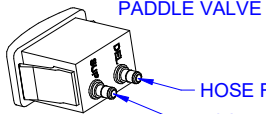

PADDLE VALVE

HOSE FROM SUPPLY
HOSE TO AIR SPRING

HOSE CONNECTION DETAIL

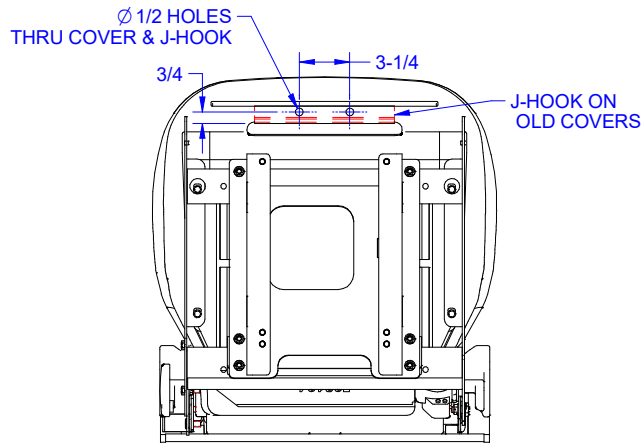

REPLACEMENT INSTRUCTIONS

1. REMOVE (2) BOLTS AND WASHERS HOLDING ICP TO SUSPENSION, REMOVE ICP, SET ASIDE.
2. REMOVE (6) BOLTS AND WASHERS HOLDING RISER TO SUSPENSION.
3. REMOVE SEAT UPPER AND RISER ASM, SET ASIDE.
4. REMOVE SKIRT WITH BRACKET OFF SUSPENSION, SET ASIDE.
5. CUT EXISTING AIR SUPPLY LINE CLOSE TO AIR SPRING.
6. REMOVE OLD SUSPENSION FROM FLOOR, DISCARD.
7. INSTALL NEW REPLACEMENT SUSPENSION TO FLOOR.
8. PLACE SKIRT WITH BRACKET ON NEW SUSPENSION, ALIGNING HOLES.
9. REPLACE AIR SUPPLY HOSE, OR ADD 18" HOSE WITH UNION TO EXISTING SUPPLY.
10. TO REWORK COVER: PULL COVER FRONT J-HOOK OFF METAL PAN, DRILL (2) HOLES (SEE DETAIL) TO ALLOW SCREWS TO THREAD INTO PAN, RE-ATTACH COVER. ALTERNATELY PURCHASE NEW CUSHION COVER, SLIT COVER MATERIAL TO ALLOW SCREWS TO THREAD INTO PAN.
11. WITH (2) SCREWS ATTACH NEW VALVE BRACKET TO CUSHION PAN, INSTALL AIR PADDLE VALVE IN BRACKET.
12. PLACE SEAT UPPER & RISER ASM ON SUSPENSION & SKIRT. RE-INSTALL (6) SCREWS AND WASHERS TO SUSPENSION.
13. CONNECT AIR SUPPLY HOSE (BLUE) TO PADDLE VALVE. CONNECT HOSE (BLACK) FROM AIR SPRING TO PADDLE VALVE.
14. RE-ATTACH ICP WITH (2) SCREWS AND WASHERS TO SUSPENSION.
15. BE SURE ALL HARDWARE HAS BEEN SECURELY FASTENED.
16. INSPECT AND TEST ALL FUNCTIONS.

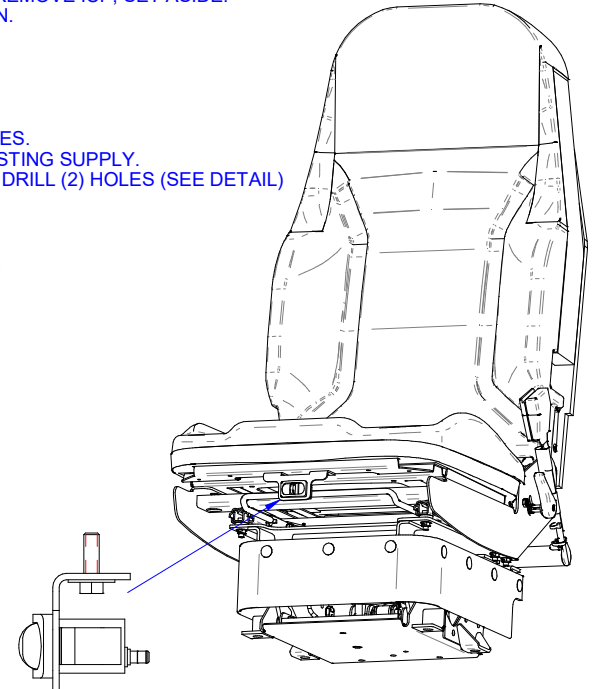

PLEASE NOTE
This drawing, owned by Seats Incorporated Reedsburg, WI, is conditionally loaned and its disclosure to the recipient is in confidence. In receiving it, the recipient agrees not to reproduce or copy it in whole or part without written consent or to furnish information from it to others or to make any use of it that is, or may be injurious or damaging to Seats Incorporated in any way, and to return it immediately upon request. Seats Incorporated

REV	DESCRIPTION	DATE	APPROVED
REVISIONS			
DIMENSIONAL TOLERANCES UNLESS OTHERWISE SPECIFIED: FRACTIONAL ± 1/2" 3 PLACE DECIMALS ± .010 2 PLACE DECIMALS ± .030 1 PLACE DECIMALS ± .50 ANGLES ± 1.0° INTERNAL FEATURES ± .003		 SEATS INCORPORATED 1515 INDUSTRIAL ST. REEDSBURG, WI 53959	
DRAWN BY		DATE	
APPROVED BY		DATE	
FILE NAME: 186094-01.dft		SIZE: B FSCM NO: 09704 PART NO: 186094	TITLE CAM SUSPENSION REPLACEMENT KIT
DO NOT SCALE PRINT		EST WEIGHT: 36.401 lbm	SHEET 3 OF 4

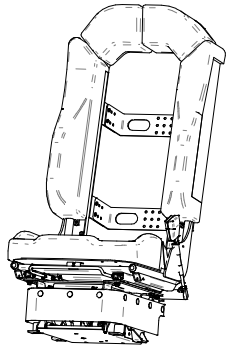

FOR SEATS WITH WOOD BOARDS

REPLACEMENT INSTRUCTIONS

1. REMOVE (2) BOLTS AND WASHERS HOLDING ICP TO SUSPENSION, REMOVE ICP, SET ASIDE.
2. REMOVE (6) BOLTS AND WASHERS HOLDING RISER TO SUSPENSION.
3. REMOVE SEAT UPPER AND RISER ASM, SET ASIDE.
4. REMOVE SKIRT WITH BRACKET OFF SUSPENSION, SET ASIDE.
5. CUT EXISTING AIR SUPPLY LINE CLOSE TO AIR SPRING.
6. REMOVE OLD SUSPENSION FROM FLOOR, DISCARD.
7. INSTALL NEW REPLACEMENT SUSPENSION TO FLOOR.
8. PLACE SKIRT WITH BRACKET ON NEW SUSPENSION, ALIGNING HOLES.
9. REPLACE AIR SUPPLY HOSE, OR ADD 18" HOSE WITH UNION TO EXISTING SUPPLY.
10. ON SEATS WITH (2) HOLES WITH T-NUTS UNDER LH SIDE FRONT OF CUSHION BOARD:
WITH (2) SCREWS 707196, ATTACH NEW OFFSET VALVE BRACKET TO CUSHION PAN,
ON SEATS WITH BOARDS THAT DO NOT HAVE (2) HOLES WITH T-NUTS UNDER LH SIDE
FRONT OF CUSHION BOARD, (BUILT PRIOR TO 6-2012):
USE (2) 781846 SCREWS AND NUT DRIVER, LOCATE OFFSET VALVE BRACKET AS
SHOWN IN DETAIL, INSTALL SCREWS INTO BOARD ATTACHING OFFSET VALVE BRACKET.
11. INSTALL AIR PADDLE VALVE IN BRACKET.
12. PLACE SEAT UPPER & RISER ASM ON SUSPENSION & SKIRT.
RE-INSTALL (6) SCREWS AND WASHERS TO SUSPENSION.
13. CONNECT AIR SUPPLY HOSE (BLUE) TO PADDLE VALVE.
CONNECT HOSE (BLACK) FROM AIR SPRING TO PADDLE VALVE.
14. RE-ATTACH ICP WITH (2) SCREWS AND WASHERS TO SUSPENSION.
15. BE SURE ALL HARDWARE HAS BEEN SECURELY FASTENED.
16. INSPECT AND TEST ALL FUNCTIONS.

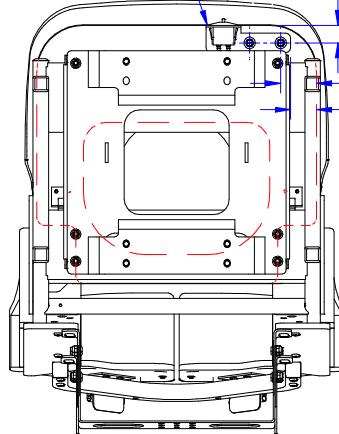
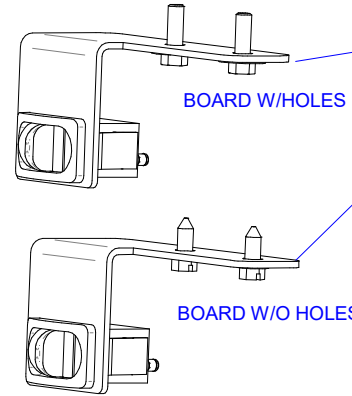
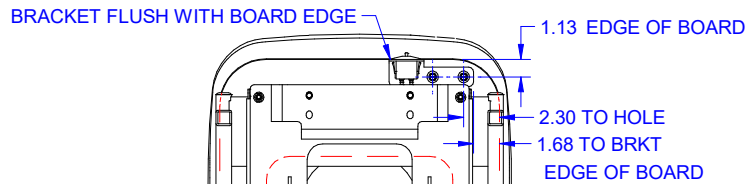
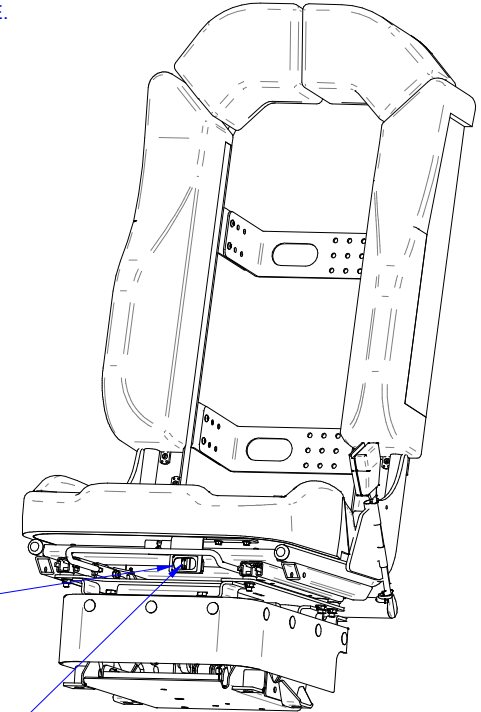
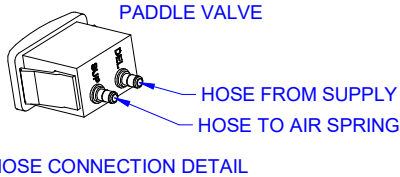

PLEASE NOTE
This drawing, owned by Seats Incorporated Reedsburg, WI, is conditionally loaned and its disclosure to the recipient is in confidence. In receiving it, the recipient agrees not to reproduce or copy it in whole or part without written consent or to furnish information from it to others or to make any use of it that is, or may be injurious or damaging to Seats Incorporated in any way, and to return it immediately upon request. Seats Incorporated

REV	DESCRIPTION	DATE	APPROVED
REVISIONS			
DIMENSIONAL TOLERANCES UNLESS OTHERWISE SPECIFIED: FRACTIONAL ± 1/2" 3 PLACE DECIMALS ± .010 2 PLACE DECIMALS ± .030 1 PLACE DECIMALS ± .50 ANGLES ± 1.0° INTERNAL FEATURES ± .003		 SEATS INCORPORATED 1515 INDUSTRIAL ST. REEDSBURG, WI 53959	
DRAWN BY		DATE	
APPROVED BY		DATE	
FILE NAME:	186094-01.dft	SIZE:	B
		FSCM NO.:	09704
		PART NO.:	186094
TITLE		CAM SUSPENSION REPLACEMENT KIT	
DO NOT SCALE PRINT		EST WEIGHT:	36.401 lbm
		SHEET 4 OF 4	